

*WIRE STRAIGHTENING
AND CUTTING MACHINES*

PDE – 102SERIES

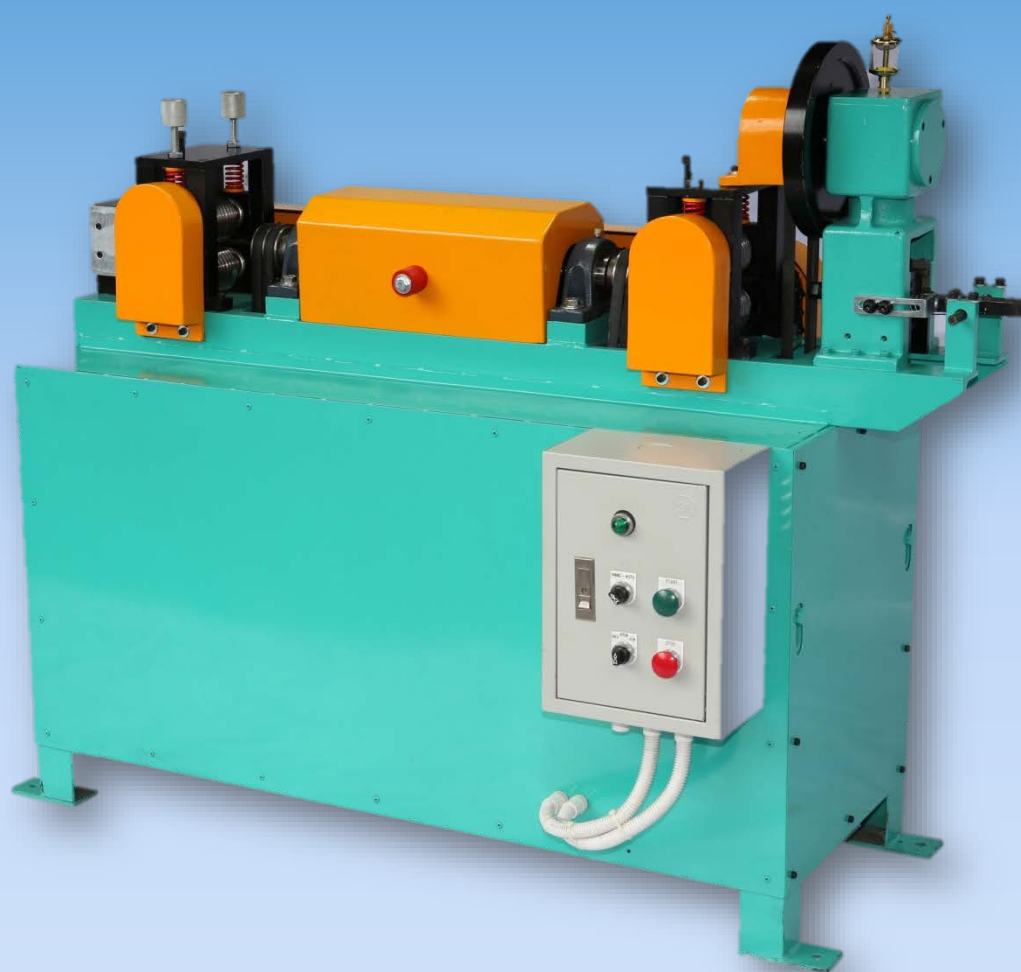

PDE

DIMENSIONS OF THE MACHINE

PDE - 102 N

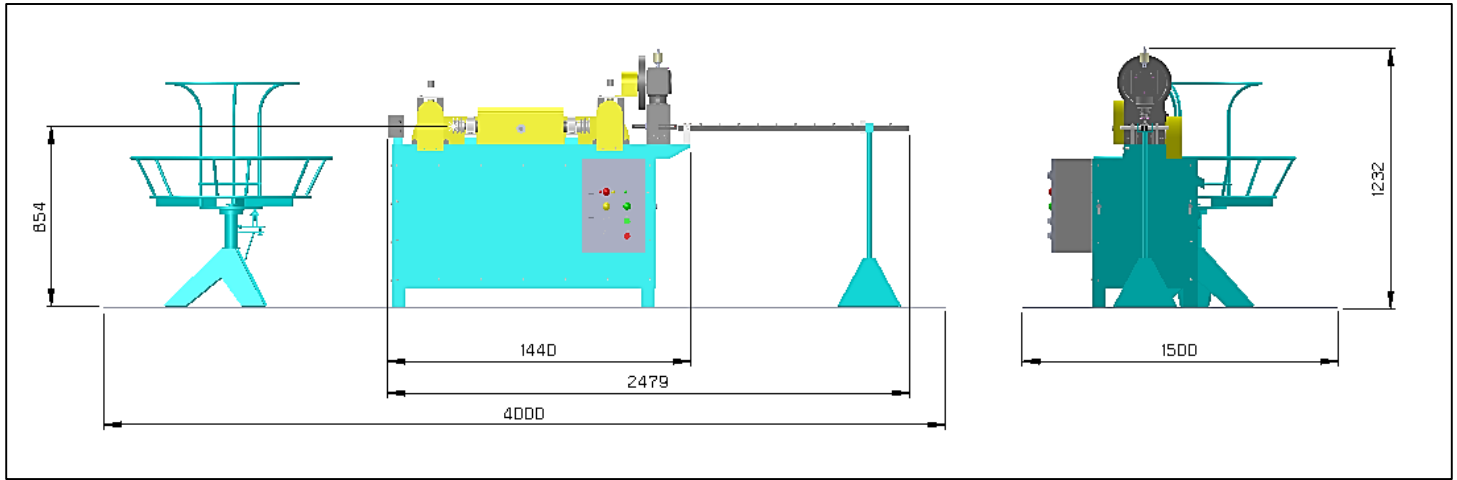

SPECIFICATION OF THE MACHINE

Item/Model	PDE – 102 N	Units.	Standard Equipment
Power	AC.380 V 3Phase	Volts	Standard equipment. -Two sets of cutting wire -The machine toolbox
Motor	5.0 +1 .0	HP.	
Wire size to cut.			
Minimum.	3.0	mm.	
Maximum	6.0	mm.	
The length of the cut.	2.0	m.	
Wire feed speed	25.0	m/min	
Size of the machine			
W x L x H	650 x 1600 x 1250	mm.	
Uncoiller	Ø 900	Ø mm.	

Produced and distributed by:

PONGDEJ ENGINEERING LTD., PART.

<http://www.pongdej.com>

Email: pongdejengineering@gmail.com

371 Suksawat Soi1 Suksawat Rd. Bangpakok Ratburana

Bangkok 10140 , Thailand.

TEL. (662) 468-1889 , 4761484 , 8768824 , (01) 919-7878

FAX. (662)476-1485

We reserve the right to change data and machine components. Without prior notice.

PDE
PONGDEJ ENGINEERING LTD.,PART.

